

CASE

Skid Steer

Engine power : 56 to 83 hp (42 to 62 kW)

Operating load : 680 to 910 kg



40_{XT}-60_{XT}-70_{XT}

C O M M I T T E D T O Y O U R N E E D S

SPECIFICATIONS AND WEIGHT

	40XT	60XT	70XT
A	2.91 m	3.09 m	3.09 m
B	0.60 m	0.54 m	0.54 m
C	1.92 m	1.95 m	1.95 m
D	1.05 m	1.10 m	1.10 m
E	3.13 m	3.23 m	3.23 m
Operating weight*	2590 kg**	2980 kg***	3130 kg***
Width over tyres	1.50 m**	1.63 or 1.80 m***	1.63 or 1.80 m***

** With operator, mechanical quick coupler, standard bucket and full fuel tank

** With 10.00 x 16.5 Solideal Hauler tyres

*** With 12.00 x 16.5 Solideal Hauler tyres

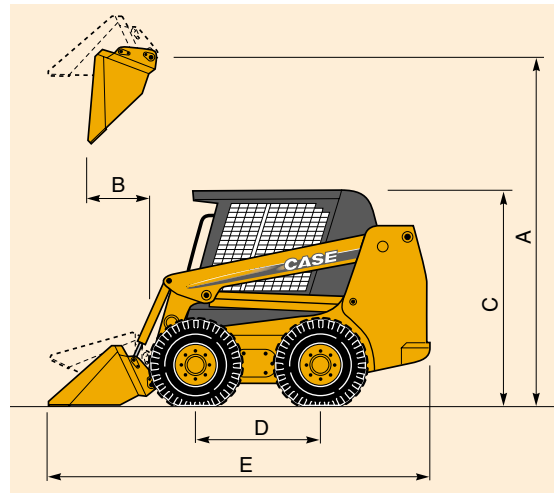

ENGINE

	40XT	60XT	70XT
Make and model	CASE 4-390	CASE 4-390	CASE 4T-390
Type	Diesel	Diesel	Turbo Diesel
EEC 80/1269 power rating	42 kW - 56 ch	45 kW - 60 ch	62 kW - 83 ch
Displacement	3.9 l	3.9 l	3.9 l
Number of cylinders	4	4	4
Rotational speed	2000 rpm	2000 rpm	2000 rpm
Cooling	Liquid	Liquid	Liquid



ELECTRICAL SYSTEM

Battery-Voltage	1 x 12 volts	1 x 12 volts	1 x 12 volts
-----------------	--------------	--------------	--------------



TRANSMISSION

Type	Hydrostatic - 4 wheel drive - Chain driven		
Hydraulic system	Double variable displacement pump - 2 fixed displacement motors		
Pump			
• Output (max.)	92 L/min.	101 L/min.	101 L/min.
Working pressure	345 bar	345 bar	345 bar
Max. travel speed (forward and reverse)	11.3 kph	11.3 kph	11.3 kph



BRAKES

Service and parking	Multi-disk oil bath type - applied whenever safety bar is raised		
---------------------	--	--	--



STEERING

Type	Hydrostatic - 360° turns possible using travel controls		
------	---	--	--



CAPACITIES

Fuel tank	83 L	83 L	83 L
Hydraulic reservoir	32.4 L	32.4 L	32.4 L
Chain case (each)	2 x 5.7 L	2 x 5.7 L	2 x 5.7 L
Engine sump with filter	10.4 L	10.4 L	10.4 L
Engine cooling system	16.6 L	16.6 L	16.6 L
Hydraulic circuit	50.2 L	50.2 L	50.2 L

LOADER HYDRAULIC SYSTEM

	40XT	60XT	70XT
Pump			
- Max. pump output	72.2 L/min.	79.4 L/min.	79.4 L/min.
Control valves	open centre, two sections		
Working pressure	207 bar	207 bar	207 bar

AUXILIARY HYDRAULIC CIRCUIT

Max. pump output	72.2 l/mn	79.4 l/mn	79.4 l/mn
Pressure	207 bar	207 bar	207 bar



LOADER ATTACHMENT PERFORMANCE

Working load	680 kg	820 kg	910 kg
Tipping load	1360 kg	1635 kg	1815 kg
Lifting force (at arm cylinders)	1685 daN	1970 daN	2075 daN
Breakout force (at buckets cylinders))	1900 daN	2250 daN	2620 daN



TYRES

SKID	MAKE TYPE	DIMENSIONS	SPECIFICATIONS	GROUND APPLICATION	MACHINE WIDTH	TYPE OF APPLICATION
40XT	Solideal "Hauler SKS"	10 x 16,5 x 8 PR	Reinforced walls & rim protection	TYRE FOR NORMAL USE General purpose	1.50 m	All STANDARD applications, (Highways, building sites, industry, agriculture, ports, rental, etc.)
	Galaxy "Beefy baby 2"	10 x 16,5 x 8 PR	Reinforced walls & rim protection, high quality XHD rubber	TYRE FOR NORMAL USE General purpose	1.50 m	All STANDARD applications, (Highways, building sites, industry, agriculture, ports, rental, etc.)
	Galaxy "Hippo"	13,0 x 16,5 x 10 PR	Reinforced walls & rim protection, high quality XHD rubber, wider than "Beefy Baby 2"	EXTRA WIDE TYRE - Soft soils, clay	1.63 m	LANDSCAPING, EARTHMOVING, in soft ground or clay
	Galaxy "King Kong"	10 x 16,5 x 10 PR	Reinforced walls and & rim protection, high quality XHD rubber, thick.	"MINING" TYPE TYRE Abrasive ground	1.50 m	MINING, INDUSTRY, RECYCLING, DEMOLITION, PORTS
60XT - 70XT	Solideal "Hauler SKS"	12 x 16,5 x 10 PR	Reinforced walls & rim protection	TYRE FOR NORMAL USE General purpose	1.63 m or 1.80 m	All STANDARD applications, (Highways, building sites, industry, agriculture, ports, rental, etc.)
	Galaxy "Beefy baby 2"	12 x 16,5 x 10 PR	Reinforced walls & rim protection, high quality XHD rubber	TYRE FOR NORMAL USE General purpose	1.63 m or 1.80 m	All STANDARD applications, (Highways, building sites, industry, agriculture, ports, rental, etc.)
	Galaxy "Hippo"	15,5 x 16,5 x 12 PR	Reinforced walls & rim protection, high quality XHD rubber, wider than "Beefy Baby 2"	EXTRA WIDE TYRE - Soft soils, clay	1.78 m	LANDSCAPING, EARTHMOVING, in soft ground or clay
	Galaxy "King Kong"	12 x 16,5 x 12 PR	Reinforced walls & rim protection, high quality XHD rubber, thick.	"MINING" TYPE TYRE Abrasive ground	1.63 m	MINING, INDUSTRY, RECYCLING, DEMOLITION, PORTS
	Galaxy "Slim Jim"	10,0 x 16,5 x 10 PR	Reinforced walls & rim protection, high quality XHD rubber, narrow	NARROW TYRE General purpose	1.50 m	Sites with MACHINE WIDTH RESTRICTIONS Industry, farms, storage areas
	Galaxy "Hulk"	12 x 16,5 x 12 PR	Reinforced walls & rim protection, high quality XHD rubber, thick	"QUARRY" TYPE TYRE Rough, dusty ground	1.63 m	QUARRIES, INDUSTRY, RECYCLING, PORTS
Galaxy "Bulky Hulk"	15,5 x 16,5 x 14 PR	Reinforced walls & rim protection, high quality XHD rubber, thick, wider than "Hulk"	"QUARRY" TYPE TYRE Rough, dusty ground	1.78 m	QUARRIES, INDUSTRY, RECYCLING, PORTS	

CAB

FOPS and ROPS approved
 Seat with operator presence detector (for safety)
 Retractable seat belt
 Safety bars with armrests
 Power assisted control levers, adjustable in position
 Throttle lever
 Halogen work lights, front and rear
 Easily cleaned cab floor

MAINTENANCE - SECURITY

Access to check areas and filters via rear hatch
 Cab tilts in less than a minute
 Engine oil and filter change reduced to 500 hrs with CASE No. 1 oil
 Parking brake automatically applied when engine stops

QUICK COUPLER

Choice between mechanical or hydraulic quick coupler

OPTIONAL EQUIPMENT

	40XT	60XT	70XT
BUCKETS			
1524 mm (choice of 4 profiles)	•		
1524 mm (choice of 5 profiles)		•	•
1676 mm (choice of 3 profiles)	•	•	•
1829 mm (choice of 4 profiles)	•		
1829 mm (choice of 5 profiles)		•	•
1981 mm (choice of 2 profiles)		•	•
2134 mm (choice of 2 profiles)	•		
2134 mm (choice of 3 profiles)		•	•
The 40, 60 and 70XT use 1845C buckets	•	•	•
HYDRAULIC SYSTEM			
High pressure, two - way circuit (207 bar/121 L/min.) (gear type pump)	•	•	•
ELECTRICAL SYSTEM			
Auxiliary electrical circuit (12 v appliance supply)	•	•	•
CONTROL			
Accelerator pedal	•	•	•
ENGINE PROTECTION			
Dust particle collector on engine air intake	•	•	•
Automatic engine shut down in event of overheating	•	•	•
CAB			
Sliding side windows	•	•	•
Windshield with windshield wiper	•	•	•
Suspension seat with seat belt	•	•	•
De luxe heater	•	•	•
SAFETY			
Rotating beacon	•	•	•
Backup alarm	•	•	•
Safety device overriding brake appliance in case of engine shut down	•	•	•
Safety type fuel tank cap	•	•	•
Cab interior mounted rearview mirror	•	•	•
ROAD TRAVEL			
Direction indicators	•	•	•
COMMODITIES			
"Ride Control"	•	•	•
Bucket hydraulic elf - levelling when raising and lowering loader	•	•	•
SUBLIMINAL TEMPERATURES			
Subliminal Temperature engine heater (240V)	•	•	•
PAINTWORK			
Special, factory applied paint finish	•	•	•

Conforms to directive 98/37/CE



NOTE: Standard and optional attachments and equipment may vary according to requirements and regulations from country to country. The photos given may show non standard or unmentioned items. Furthermore CASE reserves its right to modify specifications of its machines without prior warning, without incurring any obligation whatsoever that might result from such modifications.

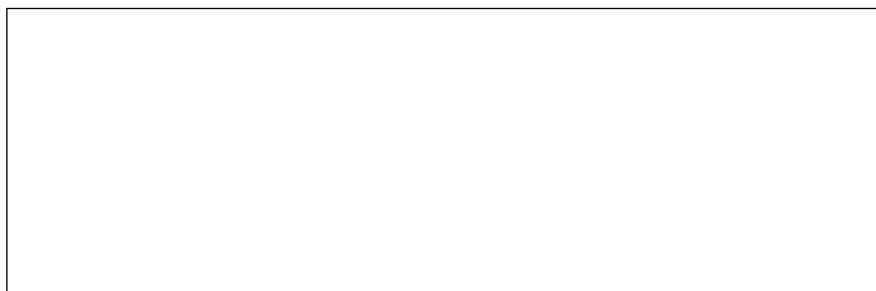

CASE

Published by **Case France**
 18, Place des Nymphéas
 Z.I. Paris Nord II
 95915 ROISSY CDG Cedex
 FRANCE
 Tel. : (33) 01 49 90 23 00
 Fax : (33) 01 49 90 26 15