



BACKHOE LOADERS

695 Super R - Series 3



Engine Horsepower	82 kW/110 hp Tier 3
Operating weight (max.)	8800 kg
Bucket capacity	1200 l

P R O F E S S I O N A L P A R T N E R

FIRST CLASS COMFORT

Case operators have always enjoyed a premium cab, and the Super R Series 3 is no exception. Floor to roof glazing offers excellent visibility to both working areas and the cab can be accessed from either side of the machine. The rear window conveniently tilts completely over the operator's head clearing his view to the work site and protects him from the rain. The 4, flat, easy to replace, side windows open partially or fully at 180° and click on one another for full adaptation to weather conditions. Twin control consoles enable the operator to monitor vital functions while working as a loader or backhoe. Series 3 brings along a document and a radio compartment located in the roof to preserve them from dust and dirt without loosing visibility, a lockable box for storage of valuables, convenient backhoe door latches and a new loader handle with progressive 4X1. All this to improve the operator's convenience, efficiency, focus and pleasure of use.

Comfort and safety. Operator satisfaction.

HEART OF THE MACHINE

The 695 Super R Series 3 is now powered by a climate friendly Tier III emissions compliant high pressure common rail version of the Case 445 TA engine. This turbocharged and intercooled 4.5 liter, 110 hp engine offers a big gain in torque to 516 Nm, boosting digging and loading performance. The engine can be diagnosed using the Case Electronic Service Tool (EST), reducing downtime and increasing productivity.

Environmentally friendly. Power to work.



POWERSHIFT

The 695 super R series 3 is equipped with a Powershift transmission as standard to increase its high loader abilities. The operator can opt for either a fully automatic or manual gear change for full control of his machine. Ergonomic location of the direction shuttle lever under left side of steering wheel means the operator will concentrate on driving the machine increasing safety, loading cycle times and reducing fatigue. Electronic autodiagnostic system reduces downtime.

Smooth shift. Robust design.

LOAD SENSING

Twin body gear pump with flow compensation circuit allows smooth use of multiple functions, for fast cycle times and high productivity. Pilot control option can be specified with additional valve and proportional control, to power attachments. Backhoe boom and swing valves have hydraulic cushioning as standard, to prolong component life and reduce shocks in the cab.

Complete control. Durable design.

4 EQUAL WHEEL STEER

The Case 695 Super R Series 3 has equal sized wheels front and rear, with three steering modes. Four wheel steering offers exceptional turning radius for manoeuvrability on site. Crab steer function ideal for trench backfilling and site clearance work. Large wheel design offers improved ground clearance, excellent traction on loose ground and smooth high speed ride. Choice of tyres available for widest range of ground conditions.

Equal wheel size. Added versatility.



SERVICE ACCESS

The engine hood easily tilts forward discovering the engine on both sides. Daily service is made easy and immediate Steering and Hydraulics pressure points located under the cab as well as all other check points are accessible from ground level for time saving service and maintenance.

Minimum downtime. Maximum productivity.

BACKHOE DESIGN



The Super R Series 3 machines have a wide stabiliser frame, offering excellent stability when digging and loading. For maximum rigidity and light weight the Case backhoe uses a robust box type boom design, with all cylinders mounted in line with the boom and dipper to spread effort and prolong component life.

There is a choice of standard or extendable dipper arms and wear pads are incorporated in the extendable hoe and the stabiliser legs to reduce downtime and wear on the machine. Customers can opt for mechanical backhoe levers or the increasingly popular pilot control system, which come with a choice of control pattern ISO or Standard actuated with a switch on the right lever column to suit the operator's efficient habit. Smooth, multifunction use of the backhoe is possible thanks to flow sharing hydraulics, resulting in reduced cycle times and less fatigue for the operator, further increasing productivity. A mechanical quick coupler is standard on all Case backhoe loaders, increasing machine versatility.

The series 3 brings new stabilisers cylinders with enlarged capacity and strength to assure massive retractive force when lifting them up, making hence sure that they never get stuck. Simultaneously clamp cylinders have been made dismantable for easy maintenance, a widely spread demand among operators and service personnel.

LOADER ABILITIES



The 695 Super R Series 3 is equipped with a 1,2 m³ loader bucket, which is 20 per cent larger than that on the 580 Super R Series 3 and 590 Super R Series 3 machines.

Mechanical self-levelling, automatic float and return to dig are all standard features of the robust loader design.

A wide choice of buckets is available, with a range of edges and teeth to match specific applications and industries. Ride control can be specified, reducing loader arm bounce during travel and increasing bucket retention. This feature also smoothes the ride for the operator, increasing travel speeds and boosting productivity.

A single lever controls the loader arm and bucket functions, while the loader performance is improved by a transmission disconnect switch built into the control lever head. This disconnect transfers full engine power to the hydraulic system for maximum breakout and digging power without wheel slippage. Mechanical self levelling that frees the operator's mind in action is standard. The 4X1 function can be safely neutralised or actuated by the flip of a switch conveniently located under the operator's thumb.

The series 3 brings a progressive 4X1 "underthumb " switch for precision and control. It is all the more appreciated than the 4X1 progressive control is also equipped with the "detent" system for continuous flow without operator's action.

ALL TERRAIN DRIVELINE



Equal sized wheels create a higher ground clearance across the entire machine. The 695 Super R Series 3 also comes with three mode steering, which allows front steer, all wheel steer, for maximum manoeuvrability, and crab steer which is particularly useful when backfilling and grading.

The front axle has sixteen degrees of oscillation and the front axle drive is automatically engaged when necessary, to ensure good traction in all ground conditions.

A choice of tyres is available to tailor the 695 Super R Series 3 to your individual ground conditions and application. A maximum turning angle of the front wheels offers a minimal turning radius of 4250 mm to the outside of the front tyres manoeuvrability on all ground conditions. The hydraulic differential lock actuated by a switch on the dashboard enhances the motricity in harsh ground condition. Optional limited slip axles make it even more performing



OPERATOR'S CAB

The 695 Super R Series 3 backhoe loader has a full width cab with floor to roof glazing for excellent visibility all round the machine. Doors on both sides provide easy access to the ROPS/FOPS cab. Two instrument consoles group the machine's vital functions, allowing the operator to monitor the machine in both loader and backhoe seating positions. An adjustable steering column (optional), comfortable operator's seat and the option of pilot controls ensure that the 695 Super R Series 3 offers a low fatigue work space. Low internal noise levels of just 77 dB(A) and a powerful heating and ventilation system provide the perfect working environment for maximum productivity. The 4 flat, easy to replace, side windows open partially or fully at 180° and click on one-another on each side for full adaptation to weather conditions.

On the single loader lever the 4x1 function can be safely neutralised or actuated by the flip of a lockswitch conveniently located under the operator's thumb.



COMMON RAIL ENGINE



The 695 Super R Series 3 is now powered by the turbocharged Case four cylinder family III engine. This Tier III compliant, climate friendly, high pressure common rail, injected, engine offers a big boost in torque, to 516 Nm, essential for high and tractive effort in tough site conditions. The engine is compatible with the Case Electronic Service Tool (EST), making fault diagnosis a simple task and reducing downtime.

FLOW SHARING HYDRAULICS



The hydraulic circuit has upgraded flow compensation hydraulics, to ensure that the operator can use multiple machine functions simultaneously. This provides smooth, rapid cycle times, reducing fatigue and effort for the driver. Load sensing hydraulics use power on demand, only moving the flow control when the operator touches the control levers. This results in lower fuel consumption and longer component life.

Pilot controls are optional, and where fitted can be equipped with an additional hydraulic valve with proportional control. This function can be used to power a wide range of aftermarket attachments, such as augers. This further increases the versatility of the Case 695 Super R Series 3, the first machine to arrive on site, and the last to leave.

By the flip of the "turtle" switch ("turtle" for hydraulic liquid reduction) on the front instrument cluster, the operator diverts the unused hydraulic fluid of the second pump to the hydraulic reservoir.

In loader application, it optimises the push power of the machine, its productivity and its comfort of use.

POWERSHIFT / 3 STEERING MODES



As befitting this top of the range machine, Case offers the 695 Super R Series 3 machine with a PowerShift transmission as standard. Owner operators and contractors looking for the ultimate in smooth gearshifting will benefit from the electronically-managed PowerShift transmission, which boosts productivity. Electronic autodiagnosics reduce downtime and ensure that the machine is always working at its optimum performance. Locking rear differential is provided for maximum traction in bad ground and, with the four wheel steering and equal sized wheels, makes the 695 Super R Series 3 unstoppable on site. Operators can select manual or automatic gear change for optimisation of work to ground conditions







SPECIFICATIONS

ENGINE

Latest generation engine, meeting European requirements for "Low exhaust emissions" Tier III in accordance with directive 97/68/EC
Make _____ CASE - FAMILY III 445TA/EGH
Type _____ Turbo-charged intercooler
& common rail high pressure injection

Engine reference number for shipping purposes only:

Make _____ CNH U.K. Limited
Type (for shipping purposes) _____ F4HE9484C*J103
Max. power ISO TR 14396 _____ 110 hp (82 kW)
Nominal rating under load _____ 2200 rpm
Maximum torque _____ 516 Nm
Rating at max. torque _____ 1400 rpm
Displacement _____ 4485 cm³
N° of cylinders _____ 4
Bore and stroke _____ 104 x 132 mm
Injection system _____ Common rail/high pressure injection
Oil filter _____ Full flow, screw-type cartridge
Air filter (dry-type) _____ 2 elements
The climate friendly engine conforms to 97/68/CE Tier 3 specifications.

TRANSMISSION

Make _____ Clark
Type _____ POWERSHIFT
Speeds _____ 4 F/2 R
Maximum travel speeds
Fwd. 1st, 2nd, 3rd and 4th _____ 6.2 - 11.8 - 23.4 and 41.4 km/h
Rev. 1st and 2nd _____ 7.5 and 14 km/h
Stall ratio of torque converter _____ 2.31 : 1
Choice of two operational modes, "manual" or "automatic", of the "PowerShift" box by simply pressing a button on the front dashboard. The forward/reverse shuttle lever is ergonomically located on the left under the steering wheel. Smooth gear changes on the move provide better operator comfort, improved transmission service life and faster cycles. The transmission control lever integrates the display of the selected speed and an outstanding electronic autodiagnostic system which dramatically reduces maintenance time.

ELECTRICAL

Voltage _____ 12 V
Battery _____ 1 x 12 V x 95 Amp./h
Alternator _____ 90 Amperes

HYDRAULICS

Type of pump _____ Gear pump
Number of bodies _____ 2
Max. flow _____ 160 l/mn
Main relief setting max. _____ 210 bar
Filtration _____ 10 micron

The hydraulic circuit combines the simplicity and sturdiness of a twin gear pump with the ease of utilisation of a "load sensing" circuit with flow compensation.

Work can be carried out in the most severe conditions and all of the hydraulic functions can be combined regardless of the load, without the operator needing to have any special aptitude or dexterity.

On the "Pilot version" an optional additional valve, which features a proportional control, is now available for special attachments (e.g. Auger).

BRAKES

Multi-disc, oil-immersed service brakes on the rear wheels, together with automatic engagement of the front wheel drive, ensure optimum safety in all travel conditions.

STEERING

Assured manoeuvrability for any type of jobsite or for travelling on the road. The switch for the steering mode offers three positions, indicated by illuminated warning lights.

The "highway" position - The "4-wheel steer" position - The "crab" steer position

MINIMUM TURNING RADIUS

At corner of 4 x 1 bucket _____ 5.32 m
At outside of the front tyre _____ 4.52 m

AXLES

OSCILLATING FRONT AXLE

Make _____ Carraro
Type _____ 26.28
Oscillation _____ 16 °
Engagement of front axle drive _____ Electric
Steering angle _____ 22°/22°

FIXED REAR AXLE

Make _____ Carraro
Type _____ 26.32 M
Steering angle _____ 22°/22°

TYRES

Standard for general use _____ 16.9 x 24 R4 12 PR ISG GY
Optional for industrial use on hard ground _____ 440/80 R28
IT530 GY

Optional for high grip _____ 440/80 R28 IT520 GY
With 4 large, equal diameter wheels, 4-wheel-drive is continuously available. The choice of tyres covers the widest range of ground conditions, and all of the traction is fully transmitted to the ground, guaranteeing the best performance at each cycle. Very good ground clearance allows obstacles to be driven over without the risk of damaging the transmission.

WEIGHT

Side-shift, with extendible dipper, 610 mm trench bucket, 4x1 loader bucket with fork, 80 kg operator
and full fuel tank _____ 8800 kg

CAPACITIES

Fuel tank _____ 135 l
Hydraulic tank _____ 70 l
Total hydraulic circuit _____ 118 l
Engine oil _____ 13 l
Fuel tank _____ 24 l
Transmission _____ 18 l
Front axle _____ 10 l
Rear axle _____ 10 l

NOISE

Internal (LpA) _____ 77 dB(A)
External (LwA) _____ 103 dB(A)

695 Super

GENERAL DIMENSIONS

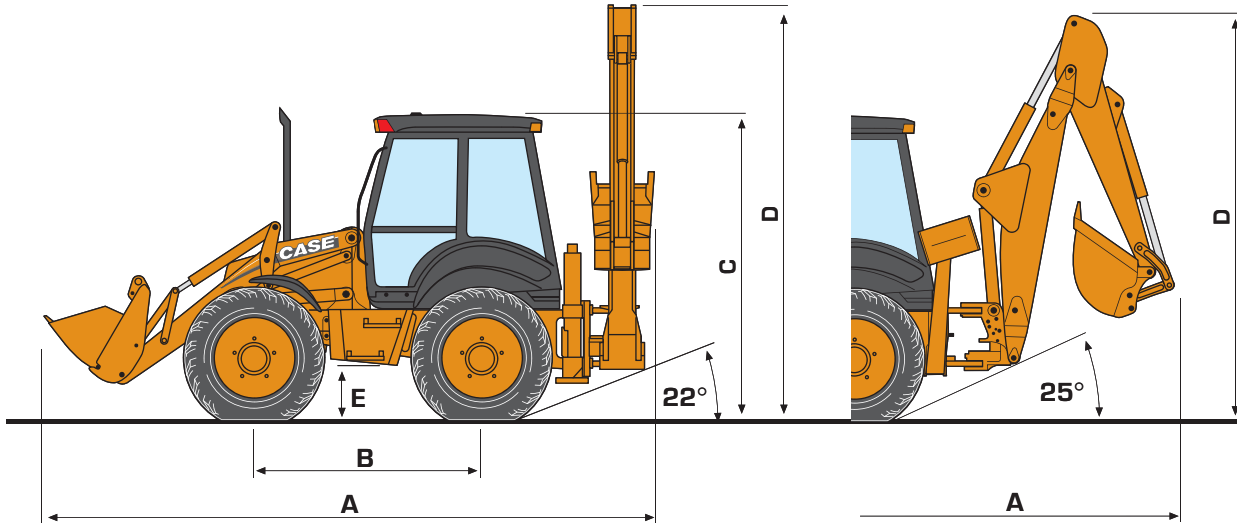

DIMENSIONS

SIDE-SHIFT

A	Overall length	m	5,75
B	Wheelbase	m	2,20
C	Height of cab	m	2,90
D	Height of boom in transport position	m	3,95
E	Ground clearance	m	0,45
	Overall width	m	2,40

BUCKETS

LOADER BUCKETS		Earthmoving	4x1	4x1 with forks
Capacity	l	1200	1200	1200
Weight	kg	435	830	990
Width	m	2,40	2,40	2,40

BACKHOE BUCKETS		279	305	406	457	610	762	914
Width	mm	279	305	406	457	610	762	914
Capacity	l	73	80	100	120	180	240	310
Weight	kg	88	140	160	165	195	225	260

R Series 3





LOADER AND BACKHOE EQUIPMENT

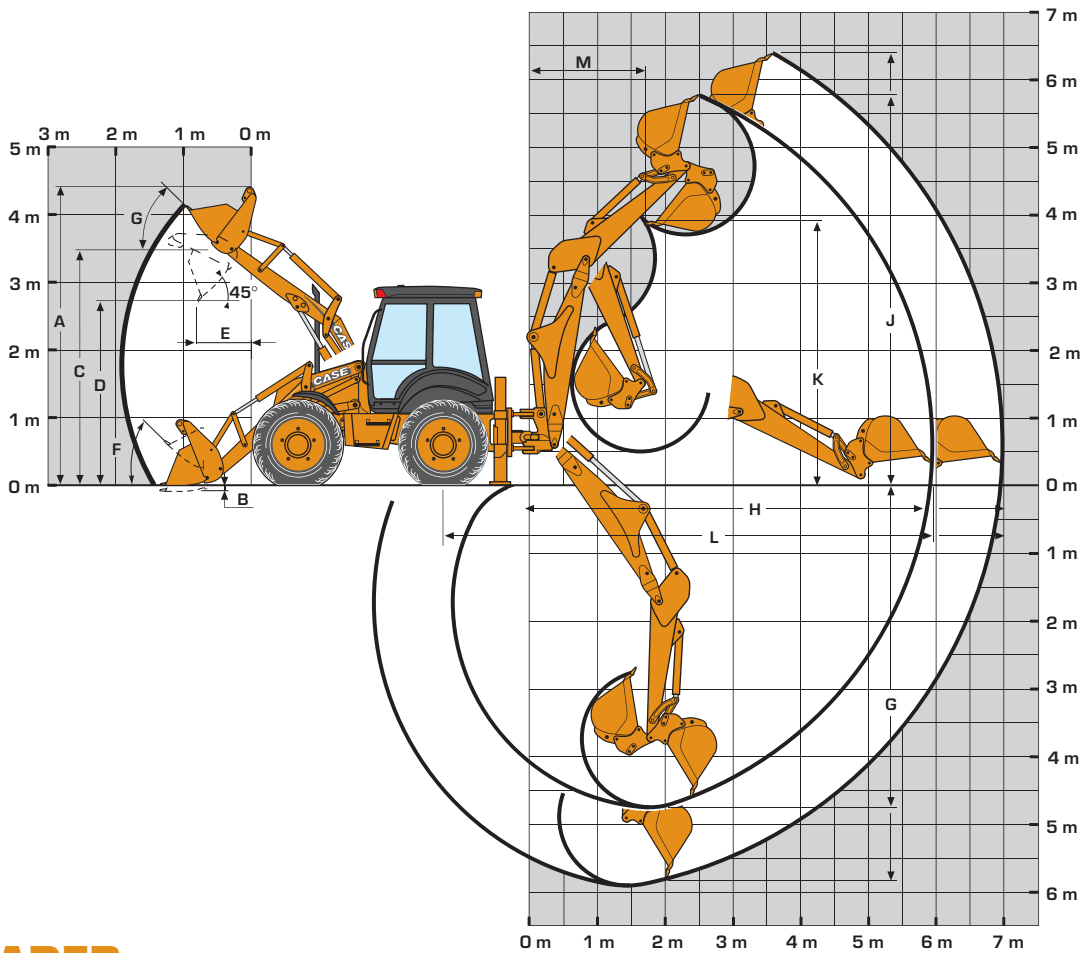

LOADER

LOADER ATTACHMENT (with R28 tyres)

		Earthmoving 1.2 m ³	4 x 1 1.2 m ³	4 x 1 with forks 1.2 m ³	
A	Overall loader height	m	4,35	4,46	5,00
B	Digging depth with bucket horizontal	mm	85	90	90
C	Hinge pin height	m	3,52	3,52	3,52
D	Dump clearance with bucket at 45°	m	2,74	2,74	2,74
E	Reach at full height with bucket at 45°	m	0,75	0,72	0,72
F	Bucket roll-back angle (on ground)		45°	45°	45°
G	Bucket roll-back angle maximum height		36,5°	47°	47°
	Breakout force - (lift cylinder)	daN	7400	7400	7400
	Breakout force - (bucket cylinder)	daN	5520	5500	5500
	Max. lift capacity	kg	4770	4580	4500
	Lift capacity to full height	kg	3500	3075	3075

HEIGHT TO GROUND

		1 m	1.5 m	2 m	2.5 m	Max
Lift capacity of forks on 4x1 at 500 mm from tyre heel	kg	2425	2250	2075	1905	1650

BACKHOE

SIDE SHIFT WITH STANDARD MECH. QUICK COUPLER

		STANDARD DIPPER	EXTENSIBLE DIPPER	
			Retracted	Extended
Swinging angle		180°	180°	180°
G	Maximum digging depth	m	4,62	5,81
H	Maximum reach from swing centre	m	5,90	6,99
J	Maximum operating height	m	5,81	6,49
K	Maximum loading height	m	3,93	4,62
L	Maximum reach from rear axle	m	7,23	8,32
M	Reach at maximum loading height	m	1,90	2,84
	Side shift off-setting from machine centreline	m	0,62	0,62
	Lift capacity at max. outreach	kg	1610	1125
	Breakout force - bucket cylinder	daN	5600	5600
	Digging force - dipper cylinder	daN	3744	2643
	Bucket rotation *	-	162-200	162-200



695 Super R Series 3

STANDARD EQUIPMENT & OPTIONS

STANDARD EQUIPMENT

Design concept

- 4 Equal wheels
- 4 Wheel Drive
- 4 Wheel Steer
- Powershift transmission
- 3 steering modes (2ws 4ws Crab)
- 1200 l loader bucket capacity

Main mechanical concepts

- Common rail Tier 3, 4,5 liter Case engine under tilting hood
- Flow sharing /load sensing hydraulics
- Centrifugal air pre-cleaner
- Switch actuated differential lock

Backhoe

- ISO pattern layout of backhoe controls
- Rigid and light box type boom with inline cylinders
- Mechanical quick coupler on backhoe
- Wear pads on stabilisers
- Hydraulic switch actuated transport lock

Loader

- Single lever loader control
- Loader automatic return to dig
- Loader float position
- Reinforced loader structure
- Mechanical self levelling on loader
- Construction or agricultural tyres in different sizes
- Dismountable clamp cylinders on slide frame

Cab

- 4 fully tilting and click-on one another side windows
- Rear - window fully tilting over operator's head
- Cloth suspension seat
- Heating and efficient defrosting
- Sun visor
- Working lights on top of cab (2 front/2 rear)
- Steering wheel spinner knob
- Reversing audible alarm
- Radio pre wiring

Safety

- Safety belt
- Safety decals

- Safety battery isolation switch
- Noise insulation meeting European CE regulations
- Tyre valve protections
- Safety strut on loader

OPTIONS

Backhoe

- Pilot controls of backhoe and stabilisers
- Two way auxiliary hydraulic circuit with pilot controls
- Extendible dipper with wear pads
- Rubber pads on stabilisers
- Hammer Circuit
- Safety valves on boom and dipper
- Safety valves on stabilisers
- Safety valve on 4x1 6x1 loader bucket
- SAE pattern
- Standard or Heavy Duty buckets

Loader

- 4X1 progressive under-thumb control with detent switch
- Choice of 1200 l buckets (std, 4x1, 6x1) with blade or teeth
- Choice of tyres (construction or agricultural pattern) and choice of sizes
- Limited slip differential
- Ride Control (amortisation of load in travel)
- Safety valves on loader
- Forks kit on 4x1

Cab

- Air conditioning
- Deluxe spring suspension seat with belt and elbow rests
- Tiltable steering column

Other

- Front wheel fenders
- Double batteries with cold start
- Muffler with spark arrestor
- Check valves on stabilisers
- Antitheft device
- Front counterweight
- Load chart decal
- Rotating beacon (roof mount)
- Basic tool kit

Standard and optional equipment shown can vary by country.

Worldwide Case Construction Equipment Contact Information

EUROPE/AFRICA/MIDDLE EAST:
Centre D'affaires EGB
5, Avenue Georges Bataille - BP 40401
60671 Le Plessis-Belleville - FRANCE

NORTH AMERICA/MEXICO:
700 State Street
Racine, WI 53404 U.S.A.

LATIN AMERICA:
Av. General David Sarnoff 2237
32210 - 900 Contagem - MG
Belo Horizonte BRAZIL

ASIA PACIFIC:
Unit 1 - 1 Foundation Place - Prospect
New South Wales - 2148 AUSTRALIA

CHINA:
No. 29, Industrial Premises, No. 376,
De Bao Road, Waigaoqiao Ftz, Pudong,
SHANGHAI, 200131, P.R.C.



The call is free from a land line. Check in advance with your Mobile Operator if you will be charged.

NOTE: Standard and optional fittings can vary according to the demands and specific regulations of each country. The illustrations may include optional rather than standard fittings - consult your Case dealer. Furthermore, CNH reserves the right to modify machine specifications without incurring any obligation relating to such changes.



Conforms to directive 98/37/CE

CASE Construction Equipment

CNH UK Ltd
Unit 4,
Hayfield Lane Business Park,
Field Lane, Auckland,
Doncaster,
DN9 3FL
Tel. 00800-2273-7373
Fax +44 1302 802829

www.casece.com

CASE
CONSTRUCTION