

# CASE

CONSTRUCTION

## BACKHOE LOADERS

### 580 Super R Series 3

### 580 Super R + Series 3 - 590 Super R Series 3



Engine Horsepower	<b>580 Super R Series 3</b> 72 kW/97 hp Tier 3	<b>580 Super R+ Series 3</b> 72 kW/97 hp Tier 3	<b>590 Super R Series 3</b> 82 kW/110 hp Tier 3
Operating weight (max.)	8140 kg	8140 kg	8140 kg
Bucket capacity	1000 l	1000 l	1000 l
Max engine torque	400 Nm	453 Nm	516 Nm

P R O F E S S I O N A L P A R T N E R

## POWER TO WORK

Super R series 3 Case offer a choice of engines on 580 super R model:

- The "580 Super R+ series 3" with a NEW tier 3, 4.5 liter, common rail, high pressure, electronically controlled, engine of 72kW. This engine develops a massive torque of 453 Nm (+ 13 % vs 580 Super R series 2/3) that gives the machine more punch to load and lift, more engine recovery.

- The "580 Super R series 3" model is equipped with a turbo aftercooled tier 3, 4.5 liter, mechanical injection, engine of 72 kW also and developing a torque of 400 Nm equal to the torque of the 580 series 2 .

**Increased torque. Power to perform.**

## OPERATOR ENVIRONMENT

The Super R Series 3 cab offers a higher degree of comfort, with ergonomically designed instruments and controls reducing fatigue for the operator. Large glass area with slim pillars offers excellent all round visibility, increasing safety on site. The new overhead radio placement and document storage combined with the new lockable storage and rear window latches make the series 3 cab even more welcoming and convenient for today's demanding operator. The rear glass is fully tiltable to give a totally unobstructed view of the digging area and protects operator from the rain in up position. All four other windows open partially or fully at 180° and click on one another for full adaptation to weather conditions. The new progressive roller-switch, with detent lock, 4X1 handle gives the operator full control of the 4X1 bucket or third hydraulic function.

**Comfort and safety. Maximum productivity.**



## LOAD SENSING

Flow compensation hydraulics allow total control of all functions by the operator, with smooth delivery and co-ordination. Hydraulic system combines the simplicity and inherent strength of a two body gear pump with the ease of use of a modular circuit. Pressure control check points are centrally located for easier system diagnosis. Backhoe boom and dipper as well as the two powerful swing cylinders have hydraulic cushioning as standard to prolong life of components and improve precision and smoothness in operation.

**Maximum durability. Complete control.**

## PILOT CONTROLS

Both 580 Super R Series 3, 580 Super R+ Series 3 and 590 Super R Series 3 can be specified with optional pilot controls, putting the backhoe levers easily into the operator's hands when facing the rear of the machine. Fully adjustable lever towers ensure a comfortable working position for any operator, while control patterns can be switched between backhoe and excavator to meet the needs of all drivers.

**Maximum comfort. Total control.**

## SERVICE ACCESS

Single piece tilting engine hood offers good access to regular service points, all of which can be reached from ground level for safety. The engine bonnet latch is inside the cab to prevent unauthorised opening. 580 Super R+ Series 3, 590 Super R Series 3 engine is compatible with Case Electronic Service Tool for rapid fault diagnosis. Its hydraulics and steering pressure control points are conveniently located between the cab and the fuel tank for easy checks.

**Ease of maintenance.  
Minimal downtime.**

## INCREASED TRACTIVE EFFORT

Both 580 Super R Series 3, 580 Super R+ Series 3 and 590 Super R Series 3 backhoe loaders are available with a new Powershuttle transmission that increases tractive effort by adopting new rear axles and improved gear ratio by 12%. PowerShift transmission is also offered to adapt the machine to specific user requirements. PowerShuttle system uses robust mechanical components for maximum durability, while PowerShift offers smooth gearshifts for increased operator convenience. On Powershift version the operator can choose manual or automatic gear change for full control of gear selection.

**Customer choice. Application specific.**

## BACKHOE DESIGN



The Case backhoe uses a robust box type boom design, combining rigidity and light weight. All cylinders are mounted in line with the boom and dipper to spread strain and prolong component life. The Super R Series 3 machines have a wide stabiliser frame, offering excellent stability even when digging to the side of the machine. With a choice of standard or extendible dipper arms the Case backhoe loader can be tailored to individual customer requirements. Wear pads are incorporated in the extendible hoe and the stabiliser legs, to reduce downtime and wear on the machine. Customers can opt for mechanical backhoe levers or the popular pilot controls. Flow sharing hydraulics enable smooth, use of the backhoe, resulting in reduced operator fatigue and faster cycle times, for increased productivity. A mechanical quick coupler is fitted as standard equipment on all Case backhoe loaders, further reducing downtime and increasing machine versatility.

Case buckets ears are designed with 2 digging holes: one for speed, one for strength for full optimisation of their use. The transport lock of the backhoe can be either mechanical or hydraulic. For safety, the Pilot controls automatically deactivate when not in use for a period of time. They are immediately reactivated at operator's will by a flick on a switch. Case Pilot controls offer in standard both ISO and SAE patterns also changeable by the flick of a switch.

## LOADER ABILITIES



The Case Super R Series 3 backhoe loader is equipped with a reinforced loader arm that features exceptional rigidity and strength. All functions are controlled by a single lever to the operator's right. This single lever operates arm lift and lower; bucket tilt and opening and closing of a 4in1 with a "detent" locking position (also called "4x1", for bucket, dozer, clamshell, scrap functions) where fitted. There is a wide choice of front buckets available for the Case backhoe loader; with high spill guards, blades or teeth.

All 4-in-1 buckets are designed to operate with a pallet fork kit if desired. The loader is equipped with an automatic return-to-dig function and mechanical self-levelling, reducing operator fatigue in repetitive digging and loading operations and minimising cycle times. To further boost productivity in ride and carry tasks, the Super R Series 3 backhoe loaders can be equipped with optional Ride Control, which reduces bounce in the loader arms during travel, aiding load retention. The 4-in-1 function conveniently located under the operator's thumb on the single lever loader control itself. The 4-in-1 buckets are pre-equipped to receive tiltable pallet fork kits. Lift hook can also be fitted as kit on bucket.

## ALL TERRAIN DRIVELINE



The 580 Super R Series 3 and 590 Super R Series 3 are all weather, all terrain machines, their four wheel drive providing traction in the worst site conditions. Customers can choose between the robust design of a mechanical PowerShuttle transmission, offering four forward and four reverse gears, or the smooth shifting PowerShift transmission that has four forward and two reverse speeds.

PowerShuttle models have a top speed of 39 kph, while Power Shift machines can manage a 40 km/h.

A 100% lockable differential is fitted to the rear axle of the Case backhoe loaders, and the front axle offers +/- 11° of oscillation, to maintain traction on the toughest terrain.

Wide front tyres are available as an option for the ultimate in cross country ability.

A maximum turning angle of the front wheels offers a minimal turning radius of 4250 mm to the outside of the front tyres for extreme maneuverability on all ground conditions.

## OPERATOR'S CAB

The Series 3 backhoe loaders have a full width cab with floor to roof glazing for excellent visibility all round the machine. Instruments and the main control panel are situated to the right of the operator, for ease of use. All of the main indicators are situated around the speedometer allowing the operator to fully concentrate when driving the machine on the road. The ROPS/FOPS cab has low internal noise levels of just 77 dB(A) and a powerful heating system provides the desired temperature in the coldest working conditions. Air conditioning is available on both Super R Series 3 machines as an option. The rear window tilts completely over the operator's head, lifting up and out of the line of sight to give the operator a clear view into the trench area. Mechanical levers or optional pilot controls give accurate, smooth control of the backhoe, while a single lever provides control of all loader and front bucket functions. The 4x1 function can be safely neutralised or actuated by the flip of a switch conveniently located under the operator's thumb. The four flat, easy to replace, side windows open partially or fully at 180° and click on one-another on each side. Optional and highly popular hydraulic pilot controls feature a safety activation switch for the choice of patterns (to adapt instantly to the operators habits) and two hydraulic finger tip stabilisers controls.



## FULL POWER



Case backhoe loaders have always been strong performers and the Series 3 models are no exception. Both 580, 580+ and 590 are equipped with powerful 4.5 liter turbo engines. The 580 Super R Series 3 offers a choice of two Tier III engines, both 72 kW but different torque characteristics: Turbo Aftercooled high pressure Common rail Electronic Injection, for a higher torque of 53 Nm ie + 13% and Turbo aftercooled with Classic Mechanical Injection. The new 590 Super R Series 3 is fitted with a Tier III compliant climate friendlier common rail injected turbocharged and intercooled version. This electronically-controlled engine offers a big boost in torque, to 516 Nm, essential for high rimpull and traction in arduous conditions. The Common Rail engines are also compatible with the Case Electronic Service Tool (EST), making fault diagnosis easier and reducing downtime.

## FLOW SHARING HYDRAULICS



In loading application upgraded flow compensation hydraulics ensure that the operator can use as many functions as possible simultaneously, ensuring smooth, rapid cycle times. The load sensing hydraulic system only uses power on demand, resulting in lower fuel consumption and longer component life. This also contributes to lower noise levels in the cab. Pilot control machines can be equipped with an additional hydraulic valve, with proportional control, that can be used to power a wide range of special attachments, such as augers. This further increases the versatility of what is already a master of many tasks on the construction site.

By the flip of the "turtle" switch ("turtle" for hydraulic liquid reduction) on the front instrument cluster, the operator diverts the unused hydraulic fluid of the second pump to the hydraulic reservoir. In loader application, it optimises the push power of the machine, its productivity and its comfort of use.

## POWER-SHUTTLE OR POWERSHIFT



To meet the different needs of customers in varied industry sectors, Case offers the Super R Series 3 machines with a choice of PowerShift or PowerShuttle transmissions. Owner operators and contractors looking for the ultimate in smooth gearshifting will benefit from the electronically-managed PowerShift transmission, while plant hire customers and those looking for ultimate durability will prefer the robust mechanical gearbox of the PowerShuttle machines, now with an increased tractive effort by adopting new rear axles and improving ratio by 12%. Whichever transmission you choose, the Super R Series 3 backhoe loaders all have a 100% locking rear differential for maximum traction in bad ground. The PowerShift versions offer the choice of fully automatic gear change or manual gear change for full control of gear selection and speed. Powershift provides smoother gear shifting and is appreciated for its forward/reverse agility in loading applications. Differential lock is mechanical in PowerShuttle version, hydraulic and actuated by a switch on dashboard for PowerShift versions.



# SPECIFICATIONS

## 580 SUPER R SERIES 3 (TIER 3)

### ENGINE

Make \_\_\_\_\_ "CNH UK Limited" ( for CASE )  
Type \_\_\_\_\_ F4GE9484C\* J602  
Capacity \_\_\_\_\_ **Turbocharged 4,5 liter**  
Number of cylinders \_\_\_\_\_ 4  
Bore x stroke \_\_\_\_\_ 104 X 132 mm  
Injection system \_\_\_\_\_ **Direct Mechanical**  
Max speed without load \_\_\_\_\_ 2430 +/- 50 rpm  
Power ISO 14396 \_\_\_\_\_ **72 kW / 97 hp**  
Rated speed under load \_\_\_\_\_ 2250 rpm  
Maximum torque EC/97/68 \_\_\_\_\_ **400 Nm**  
Speed at maximum torque \_\_\_\_\_ 1400 rpm  
Air filter \_\_\_\_\_ Dry type - two elements  
Oil filter \_\_\_\_\_ Full flow type with screw on element  
The engine conforms to 97/68/CE **Tier 3** standards for reduced pollution.  
Their reliability and low cost of operation are a byword among Case users.

### TRANSMISSION

Two types of transmission  
**POWERSHUTTLE**  
Type \_\_\_\_\_ PowerShuttle  
Speeds \_\_\_\_\_ 4 FWD/4 REV  
Maximum speeds  
FWD 1st, 2nd, 3rd and 4th \_\_\_\_\_ 6.4 - 10.3 - 21.9 and 39 kph  
REV 1st, 2nd, 3rd and 4th \_\_\_\_\_ 7.6 - 12.3 - 26.2 and 40 kph  
Torque converter stall ratio \_\_\_\_\_ 2.31:1  
Simplicity is also synonymous with strength, that is why CASE uses a mechanical gearbox on its backhoe-loader. It has been tested over long periods and the latest version is the result of long experience.  
**POWERSHIFT**  
Type \_\_\_\_\_ PowerShift  
Speed \_\_\_\_\_ 4 FWD/2 REV  
Maximum travel speeds  
1st, 2nd, 3rd and 4th \_\_\_\_\_ 6.3 - 11.8 - 23.4 et 40 kph  
1st and 2nd \_\_\_\_\_ 7.5 and 14.0 kph  
Stall ratio of torque converter \_\_\_\_\_ 2.31:1  
The management of the "PowerShift" gearbox provides smooth gearshifts, using synchronised gears for longer life of the mechanical parts and increased convenience for the operator. The inverter lever is ergonomically located to the left of the steering wheel.

### ELECTRICAL

Voltage \_\_\_\_\_ 12 Volts  
Battery \_\_\_\_\_ 1 x 12 V x 95 Amp/h  
Alternator \_\_\_\_\_ 90 Amp

### HYDRAULICS

Type of pump \_\_\_\_\_ Gear  
Number of bodies \_\_\_\_\_ 2  
**Maximum flow** \_\_\_\_\_ 160 l/min  
Maximum pressure level \_\_\_\_\_ 210 bar

Filtration \_\_\_\_\_ 7 micron  
The hydraulic system combines the simplicity and strength of a two body gear pump with the ease of use of a modular type circuit.

### BRAKES

Multi-disc, oil-immersed service brakes on the rear wheels, together with automatic engagement of the front wheel drive, ensure optimum safety in all travel conditions.  
Disc diameter \_\_\_\_\_ 203 mm  
Total friction area \_\_\_\_\_ 2878 cm<sup>2</sup>

### STEERING

Turning radius  
at ext. edge of front tyres \_\_\_\_\_ 4250 mm  
at bucket corner \_\_\_\_\_ 5525 mm  
at bucket tooth \_\_\_\_\_ 5625 mm  
Note: front tyres 12.5/80-18, wheel not braked, 4WD engaged

### AXLES

**FIXED REAR AXLE**  
Lockable differential \_\_\_\_\_ 100%  
**4WD OSCILLATING FRONT AXLE**  
Oscillation \_\_\_\_\_ 11°/11°

### TYRES

4WD Front \_\_\_\_\_ 12.5/80 x 18  
\_\_\_\_\_ 320/80 x 18 (IT520)  
4WD Rear \_\_\_\_\_ 18.4 x 26  
\_\_\_\_\_ 16.9 x 28  
\_\_\_\_\_ 480/80 x 26 (IT520)

### WEIGHT

In the Sideshift version, with the standard tooth loader bucket, 610 mm rear bucket, full fuel tank and operator (75 kg).  
4 WD, standard dipper/Ext. \_\_\_\_\_ 7910 kg  
4 WD, extendible dipper/Ext. \_\_\_\_\_ 8140 kg

### CAPACITIES

Fuel tank \_\_\_\_\_ 128 l  
Hydraulic reservoir \_\_\_\_\_ 55 l  
Total hydraulic circuit \_\_\_\_\_ 118 l  
Engine oil \_\_\_\_\_ 13.6 l  
Cooling system \_\_\_\_\_ 24 l  
Gear box oil \_\_\_\_\_ 18 l  
Front axle 4WD  
Differential \_\_\_\_\_ 7.0 l  
Final reduction \_\_\_\_\_ 0.7 + 0.7 l  
Rear axle 4WD  
Total \_\_\_\_\_ 22.0 l

The high capacity fuel tank provides long periods of work between fill-ups to reduce stoppage time.

### NOISE

Internal (LpA) \_\_\_\_\_ 77 dB(A)  
External (LwA) \_\_\_\_\_ 103 dB(A)

# 580 Super R Series 3

# SPECIFICATIONS

## 580 SUPER R+ SERIES 3 (TIER 3)

### ENGINE

Make \_\_\_\_\_ "CNH UK Limited" ( for CASE )  
 Type \_\_\_\_\_ F4H80484G\*J102  
 Capacity **Turbocharged High Pressure Common Rail 4,5 liter**  
 Number of cylinders \_\_\_\_\_ 4  
 Bore x stroke \_\_\_\_\_ 104 X 132 mm  
 Injection system \_\_\_\_\_ **Electronic**  
 Max speed without load \_\_\_\_\_ 2430 +/- 50 rpm  
 Power ISO 14396 \_\_\_\_\_ **72 kW / 97 hp**  
 Rated speed under load \_\_\_\_\_ 2250 rpm  
 Maximum torque EC/97/68 \_\_\_\_\_ **453 Nm**  
 Speed at maximum torque \_\_\_\_\_ 1400 rpm  
 Air filter \_\_\_\_\_ Dry type - two elements  
 Oil filter \_\_\_\_\_ Full flow type with screw-on element

**CASE E.S.T. ( Electronic Service Tool ) compatible.**

The engine conforms to 97/68/CE **Tier 3** (standards for reduced pollution).

Their reliability and low cost of operation are a byword among Case users.

### TRANSMISSION

Two types of transmission

#### POWERSHUTTLE

Type \_\_\_\_\_ PowerShuttle  
 Speeds \_\_\_\_\_ 4 FWD/4 REV  
 Maximum speeds  
 FWD 1st, 2nd, 3rd and 4th \_\_\_\_\_ 6.4 - 10.3 - 21.9 and 39 kph  
 REV 1st, 2nd, 3rd and 4th \_\_\_\_\_ 7.6 - 12.3 - 26.2 and 40 kph  
 Torque converter stall ratio \_\_\_\_\_ 2.31:1

Simplicity is also synonymous with strength, that is why CASE uses a mechanical gearbox on its backhoe-loader. It has been tested over long periods and the latest version is the result of long experience.

#### POWERSHIFT

Type \_\_\_\_\_ PowerShift  
 Speed \_\_\_\_\_ 4 FWD/2 REV  
 Maximum travel speeds  
 1st, 2nd, 3rd and 4th \_\_\_\_\_ 6.3 - 11.8 - 23.4 et 40 kph  
 1st and 2nd \_\_\_\_\_ 7.5 and 14.0 kph  
 Stall ratio of torque converter \_\_\_\_\_ 2.31:1  
 The management of the "PowerShift" gearbox provides smooth gearshifts, using synchronised gears for longer life of the mechanical parts and increased convenience for the operator. The inverter lever is ergonomically located to the left of the steering wheel.

### ELECTRICAL

Voltage \_\_\_\_\_ 12 Volts  
 Battery \_\_\_\_\_ 1 x 12 V x 95 Amp/h  
 Alternator \_\_\_\_\_ 90 Amp

### HYDRAULICS

Type of pump \_\_\_\_\_ Gear  
 Number of bodies \_\_\_\_\_ 2  
**Maximum flow** \_\_\_\_\_ 160 l/min  
 Maximum pressure level \_\_\_\_\_ 210 bar  
 Filtration \_\_\_\_\_ 7 micron

The hydraulic system combines the simplicity and strength of a two body gear pump with the ease of use of a modular type circuit.

### BRAKES

Multi-disc, oil-immersed service brakes on the rear wheels, together with automatic engagement of the front wheel drive, ensure optimum safety in all travel conditions.

Disc diameter \_\_\_\_\_ 203 mm  
 Total friction area \_\_\_\_\_ 2878 cm<sup>2</sup>

### STEERING

Turning radius  
 at ext. edge of front tyres \_\_\_\_\_ 4250 mm  
 at bucket corner \_\_\_\_\_ 5525 mm  
 at bucket tooth \_\_\_\_\_ 5625 mm

Note: front tyres 12.5/80-18, wheel not braked, 4WD engaged

### AXLES

#### FIXED REAR AXLE

Lockable differential \_\_\_\_\_ 100%

#### 4WD OSCILLATING FRONT AXLE

Oscillation \_\_\_\_\_ 11°/11°

### TYRES

4WD Front \_\_\_\_\_ 12.5/80 x 18  
 \_\_\_\_\_ 320/80 x 18 (IT520)  
 4WD Rear \_\_\_\_\_ 18.4 x 26  
 \_\_\_\_\_ 16.9 x 28  
 \_\_\_\_\_ 480/80 x 26 (IT520)

### WEIGHT

In the Sideshift version, with the standard tooth loader bucket, 610 mm rear bucket, full fuel tank and operator (75 kg).

4 WD, standard dipper/Ext. \_\_\_\_\_ 7910 kg

4 WD, extendible dipper/Ext. \_\_\_\_\_ 8140 kg

### CAPACITIES

Fuel tank \_\_\_\_\_ 128 l  
 Hydraulic reservoir \_\_\_\_\_ 55 l  
 Total hydraulic circuit \_\_\_\_\_ 118 l  
 Engine oil \_\_\_\_\_ 13.6 l  
 Cooling system \_\_\_\_\_ 24 l  
 Gear box oil \_\_\_\_\_ 18 l  
 Front axle 4WD  
 Differential \_\_\_\_\_ 7.0 l  
 Final reduction \_\_\_\_\_ 0.7 + 0.7 l  
 Rear axle 4WD  
 Total \_\_\_\_\_ 22.0 l

The high capacity fuel tank provides long periods of work between fill-ups to reduce stoppage time.

### NOISE

Internal (LpA) \_\_\_\_\_ 77 dB(A)  
 External (LwA) \_\_\_\_\_ 103 dB(A)

# 580 Super R+ Series 3

# GENERAL DIMENSIONS

## 580 Super R Series 3

## 580 Super R+ Series 3

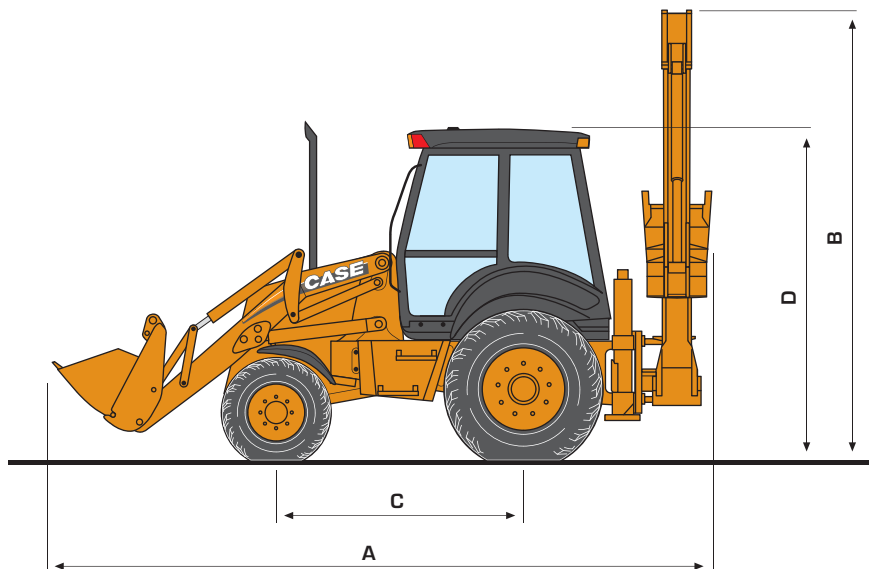

### DIMENSIONS

#### SIDE-SHIFT

<b>A</b>	Overall length - with standard bucket	m	5.77
<b>B</b>	Boom height transport position	m	3.90
<b>C</b>	Wheelbase	m	2.18
<b>D</b>	Cab height	m	2.90
	Overall width - with standard bucket	m	2.43
	Width outside tyres	m	2.23
	Stabiliser levelling compensation angle		14°

## BUCKETS

### LOADER BUCKETS

		Std	4/1	6/1
Capacity	l	1000	1000	1000
Weight	kg	415	800	960
Width at blade	m	2.25	2.25	2.25

### BACKHOE BUCKETS

Width	mm	300	400	450	610	750	900
Weight	kg	92	106	114	134	152	172

# 580 580+



# SPECIFICATIONS

## 590 SUPER R SERIES 3 (TIER 3)

### ENGINE

Make \_\_\_\_\_ "CNH UK Limited" ( for CASE )  
 Type \_\_\_\_\_ F4HE9484C\*J102  
 Capacity **Turbocharged High Pressure Common Rail 4,5 liter**  
 Number of cylinders \_\_\_\_\_ 4  
 Bore x stroke \_\_\_\_\_ 104 X 132 mm  
 Injection system \_\_\_\_\_ **Electronic**  
 Max speed without load \_\_\_\_\_ 2430 +/- 50 rpm  
 Power ISO 14396 \_\_\_\_\_ **82 kW / 110 hp**  
 Rated speed under load \_\_\_\_\_ 2250 rpm  
 Maximum torque EC/97/68 \_\_\_\_\_ **516 Nm**  
 Speed at maximum torque \_\_\_\_\_ 1400 rpm  
 Air filter \_\_\_\_\_ Dry type - two elements  
 Oil filter \_\_\_\_\_ Full flow type with screw-on element

**CASE E.S.T. Electronic Service Tool ) compatible.**

The engine conforms to 97/68/CE **Tier 3** standards for reduced pollution.

Their reliability and low cost of operation are a byword among Case users.

### TRANSMISSION

Two types of transmission

#### POWERSHUTTLE

Type \_\_\_\_\_ PowerShuttle  
 Speeds \_\_\_\_\_ 4 FWD/4 REV  
 Maximum speeds  
 FWD 1st, 2nd, 3rd and 4th \_\_\_\_\_ 6.4 - 10.3 - 21.9 and 39 kph  
 REV 1st, 2nd, 3rd and 4th \_\_\_\_\_ 7.6 - 12.3 - 26.2 and 46.4 kph  
 Torque converter stall ratio \_\_\_\_\_ 2.31:1

Simplicity is also synonymous with strength, that is why CASE uses a mechanical gearbox on its backhoe-loader. It has been tested over long periods and the latest version is the result of long experience.

#### POWERSHIFT

Type \_\_\_\_\_ PowerShift  
 Speed \_\_\_\_\_ 4 FWD/2 REV  
 Maximum travel speeds  
 1st, 2nd, 3rd and 4th \_\_\_\_\_ 6.3 - 11.8 - 23.4 et 41.4 kph  
 1st and 2nd \_\_\_\_\_ 7.5 and 14.0 kph  
 Stall ratio of torque converter \_\_\_\_\_ 2.31:1

The management of the "PowerShift" gearbox provides smooth gearshifts, using synchronised gears for longer life of the mechanical parts and increased convenience for the operator. The inverter lever is ergonomically located to the left of the steering wheel.

### ELECTRICAL

Voltage \_\_\_\_\_ 12 Volts  
 Battery \_\_\_\_\_ 1 x 12 V x 95 Amp/h  
 Alternator \_\_\_\_\_ 90 Amp

### HYDRAULICS

Type of pump \_\_\_\_\_ Gear  
 Number of bodies \_\_\_\_\_ 2  
**Maximum flow** \_\_\_\_\_ 170 l/min  
 Maximum pressure level \_\_\_\_\_ 210 bar  
 Filtration \_\_\_\_\_ 7 micron

The hydraulic system combines the simplicity and strength of a two body gear pump with the ease of use of a modular type circuit.

### BRAKES

Multi-disc, oil-immersed service brakes on the rear wheels, together with automatic engagement of the front wheel drive, ensure optimum safety in all travel conditions.

Disc diameter \_\_\_\_\_ 203 mm  
 Total friction area \_\_\_\_\_ 2878 cm<sup>2</sup>

### STEERING

Turning radius  
 at ext. edge of front tyres \_\_\_\_\_ 4250 mm  
 at bucket corner \_\_\_\_\_ 5525 mm  
 at bucket tooth \_\_\_\_\_ 5625 mm  
 Note: front tyres 12.5/80-18, wheel not braked, 4WD engaged

### AXLES

#### FIXED REAR AXLE

Lockable differential \_\_\_\_\_ 100%

#### 4WD OSCILLATING FRONT AXLE

Oscillation \_\_\_\_\_ 11°/11°

### TYRES

4WD Front \_\_\_\_\_ 12.5/80 x 18  
 \_\_\_\_\_ 320/80 x 18 (IT520)  
 4WD Rear \_\_\_\_\_ 18.4 x 26  
 \_\_\_\_\_ 16.9 x 28  
 \_\_\_\_\_ 480/80 x 26 (IT520)

### WEIGHT

In the Sideshift version, with the standard tooth loader bucket, 610 mm rear bucket, full fuel tank and operator (75 kg).  
 4 WD, standard dipper/Ext. \_\_\_\_\_ kg 7910/8140

### CAPACITIES

Fuel tank \_\_\_\_\_ 128 l  
 Hydraulic reservoir \_\_\_\_\_ 55 l  
 Total hydraulic circuit \_\_\_\_\_ 118 l  
 Engine oil \_\_\_\_\_ 13.6 l  
 Cooling system \_\_\_\_\_ 24 l  
 Gear box oil \_\_\_\_\_ 18 l  
 Front axle 4WD  
 Differential \_\_\_\_\_ 7.0 l  
 Final reduction \_\_\_\_\_ 0.7 + 0.7 l  
 Rear axle 4WD  
 Total \_\_\_\_\_ 22.0 l

The high capacity fuel tank provides long periods of work between fill-ups to reduce stoppage time.

### NOISE

Internal (LpA) \_\_\_\_\_ 77dB(A)  
 External (LwA) \_\_\_\_\_ 103 dB(A)  
 Eventough scientific evaluations of noise levels are identical to the 580 Super R Series 2 engine, operators and by-standers tend to perceive noise level of the 590 Super R Series 2 as "softer".

# 590 Super

# GENERAL DIMENSIONS

## 590 Super R Series 3

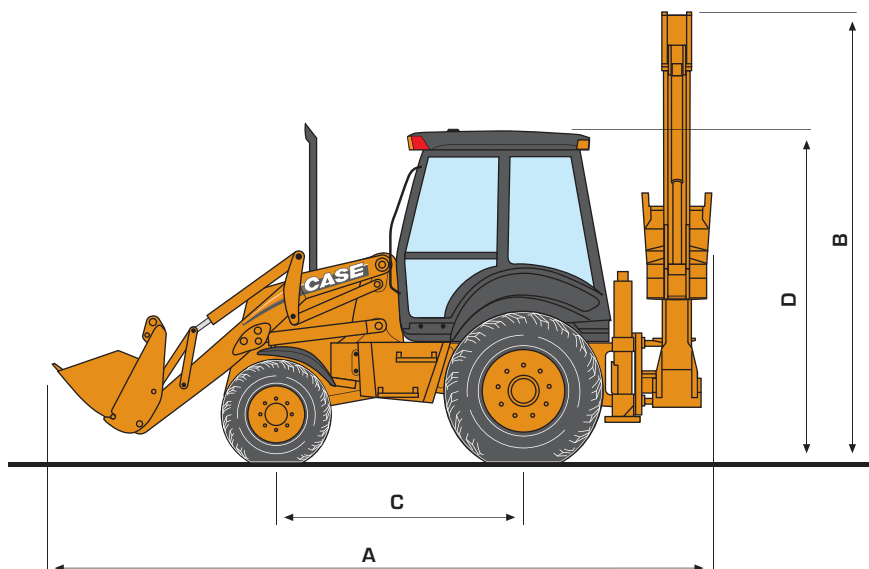

### DIMENSIONS

#### SIDE-SHIFT

<b>A</b>	Overall length - with standard bucket	m	5.77
<b>B</b>	Boom height transport position	m	3.90
<b>C</b>	Wheelbase	m	2.18
<b>D</b>	Cab height	m	2.90
	Overall width - with standard bucket	m	2.43
	Width outside tyres	m	2.23
	Stabiliser levelling compensation angle		14°

## BUCKETS

### LOADER BUCKETS

		Std	4/1	6/1
Capacity	l	1000	1000	1000
Weight	kg	415	800	960
Width at blade	m	2.25	2.25	2.25

### BACKHOE BUCKETS

Width	mm	300	400	450	610	750	900
Weight	kg	92	106	114	134	152	172

# R Series 3

# LOADER AND BACKHOE EQUIPMENT

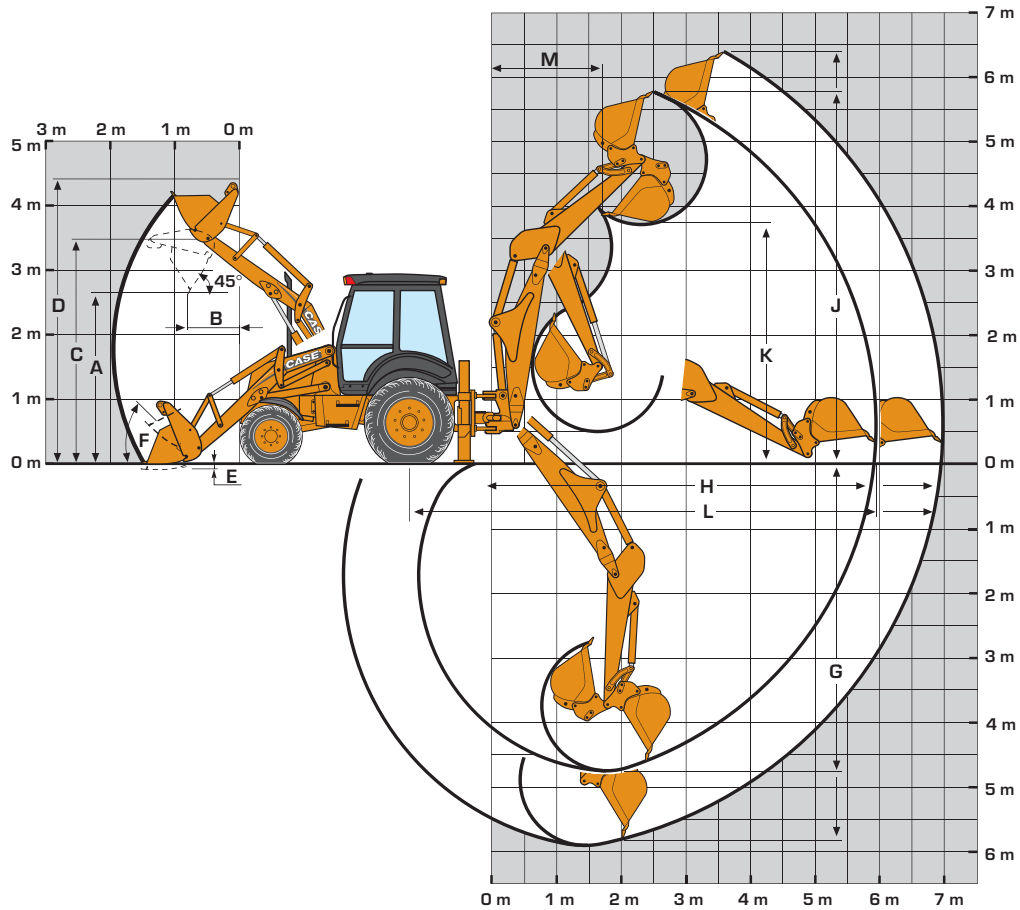

## LOADER

### LOADER ATTACHMENT

		Digging bucket	4 in 1 bucket	
A	Maximum dump height under bucket at 45°	mm	2685	2693
B	Maximum reach with bucket at 45°	mm	830	813
C	Maximum height pin	mm	3460	3458
D	Maximum bucket height	mm	4250	4405
E	Horizontal bucket digging depth	mm	120	125
F	Bucket angle (on ground)		43°	43°
	Bucket angle (in the transport position)		46°	46°
	Lift capacity (at bucket load centre of gravity)	kg	4830	4610
	Maximum height lifting capacity	kg	3450	3195
	Lift force (boom cylinders)	daN	4050	4070
	Breakout force (bucket cylinders)	daN	6545	6650

Dimensions and specifications measured as per SAE J 732 c standard using a 4WD backhoe loader.

HEIGHT TO GROUND		1 m	1.5 m	2 m	2.5 m	Max
Lift capacity of forks on 4x1 at 500 mm from tyre heel	kg	2425	2250	2075	1895	1685

## BACKHOE

	CASE STANDARD MECHANICAL QUICK COUPLER			
	STANDARD DIPPER	EXTENDIBLE DIPPER		
		Retracted	Extended	
Swinging angle	180°	180°	180°	
G	Maximum digging depth	mm	4612	5799
H	Maximum reach from swing centre	mm	5906	6992
J	Maximum operating height	mm	5837	6537
K	Load height	mm	3917	4645
L	Maximum reach at rear axle	mm	7231	8317
M	Capacity at maximum load height	mm	1828	2757
	Central offset	m	0.62	0.62
	Lift capacity at max outreach	kg	1495	1090
	Breakout force (bucket cylinder)	daN	5603	5603
	Digging force (dipper cylinder)	daN	3744	2643
	Bucket rotation*		162 - 200	162 - 200

\* Force - speed bucket hole



# 580-590 Super R Series 3 580 Super R+ Series 3

## STANDARD EQUIPMENT & OPTIONS

### STANDARD EQUIPMENT

#### Design

- 97 hp (580), 97 hp Common rail (580+) and 110 hp common rail (590) Case 4.5 turbo engine
- 4 wheel drive
- Powershuttle or Powershift transmission
- Flow sharing / Load sensing hydraulics
- 1000 l loader bucket capacity
- Centrifugal air pre-cleaner
- Rear differential lock

#### Backhoe

- ISO pattern layout of backhoe controls
- Rigid and light box type boom with inline cylinders
- Mechanical quick coupler on backhoe
- Wear pads on stabilisers
- Mechanical transport lock
- Dismountable clamp cylinders
- Angled sliding rail on slide frame

#### Loader

- Single lever with 4X1 thumb control with detent
- Loader automatic return to dig
- Loader float position
- Reinforced loader structure
- Mechanical self levelling on loader
- Construction or agricultural tyres in different sizes
- Self storing loader strut

#### Cab

- 4 fully tilting and click-on oneanother side windows
- Fully tilting over rear - window
- With door latches
- Heating and efficient defrosting
- Sun visor
- Working lights on top of cab (2 front / 2 rear)
- Cloth suspension seat
- Steering wheel spinner knob
- Reversing audible alarm

- Radio pre wiring
- Radio compartment
- Document compartment
- Lockable storage
- **Safety**
- Seat belt
- Safety decals
- Battery isolation switch
- Noise insulation meeting european CE regulations
- Tyre valve protections
- Safety strut on loader

### OPTIONS

#### Backhoe

- Pilot hydraulic controls SAE/ISO for backhoe & stabilizers
- Two way auxiliary hydraulic circuit with pilot controls
- Extendible dipper with wear pads
- Rubber pads on stabilisers
- Hammer circuit
- Safety valves on boom and dipper
- Safety valves on stabilisers
- SAE pattern for mechanical backhoe controls
- Lifting hook on dipper
- Hydraulic transport lock
- Standard or Heavy Duty buckets
- Overload warning buzzer
- **Loader**
- Choice of buckets (std, 4x1, 6x1) with blade or teeth
- Choice of tyres (construction or agricultural pattern)
- Choice of tyre sizes
- Limited slip differential
- Ride Control (amortisation of load in travel)
- Safety valves on loader
- Forks kit on 4x1

- Check valves for 4x1, 6x1 buckets
- **Cab**
- Air conditioning
- Additional working lights (2 front)
- Additional working lights (2 rear)
- Deluxe spring suspension seat with belt and elbow rests
- Tiltable steering wheel
- Internal fan
- Roof plate holder
- Right hand rear view mirror
- **Other**
- Front wheel fenders
- Double batteries with cold start
- Remote battery terminals
- Muffler with spark arrestor
- Stabilisers lock out valves
- Antitheft device
- Antitheft lock 4 wd
- Front counterweight
- Load chart decal
- Rotating beacon (roof mount)
- Basic tool kit

Standard and optional equipment shown can vary by country.

#### Worldwide Case Construction Equipment Contact Information

**EUROPE/AFRICA/MIDDLE EAST:**  
Centre D'affaires EGB  
5, Avenue Georges Bataille - BP 40401  
60671 Le Plessis-Belleville - FRANCE

**NORTH AMERICA/MEXICO:**  
700 State Street  
Racine, WI 53404 U.S.A.

**LATIN AMERICA:**  
Av. General David Sarnoff 2237  
32210 - 900 Contagem - MG  
Belo Horizonte BRAZIL

**ASIA PACIFIC:**  
Unit 1 - 1 Foundation Place - Prospect  
New South Wales - 2148 AUSTRALIA

**CHINA:**  
No. 29, Industrial Premises, No. 376,  
De Bao Road, Waigaoqiao Ftz, Pudong,  
SHANGHAI, 200131, P.R.C.



The call is free from a land line. Check in advance with your Mobile Operator if you will be charged.

**NOTE:** Standard and optional fittings can vary according to the demands and specific regulations of each country. The illustrations may include optional rather than standard fittings - consult your Case dealer. Furthermore, CNH reserves the right to modify machine specifications without incurring any obligation relating to such changes.



Conforms to directive 98/37/CE

**CASE Construction Equipment**  
CNH UK Ltd  
Unit 4,  
Hayfield Lane Business Park,  
Field Lane, Auckland,  
Doncaster,  
DN9 3FL  
Tel. 00800-2273-7373  
Fax +44 1302 802829

[www.casece.com](http://www.casece.com)

**CASE**  
CONSTRUCTION